

CAT. NO.	RUN	TAP	A	B	C	TAP NUT
HLB-400	#6 SOL - 400 MCM	#6 SOL - 4/0 STR	6.50	1.75 [44]	2.50 [64]	3/4
HLB-800	4/0 SOL- 800 MCM	#4 SOL - 350MCM	[165]	2.00 [51]	3.00 [76]	

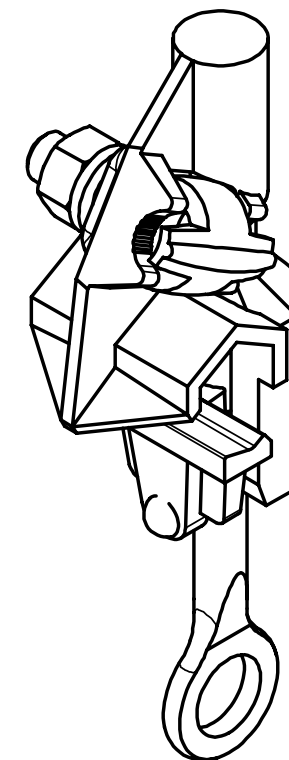

MATERIAL: BRONZE BODY  
TAP AND RUN - COPPER.

					TO ORDER CMC PRODUCTS CALL 1-513-860-4455	DRAWN BY: <b>TS</b> 09-12-19	NAME OF PART: <b>HOT LINE CLAMP</b>	CAT. NO.: SEE TABLE
					FOR PRODUCT INFO: <a href="http://www.cmclugs.com">http://www.cmclugs.com</a>	CHECKED BY:	DWG NO: C58701437-S (CHARTED)	<b>A</b>
<b>A</b>	NEW DRAWING CREATED		09-12-19	TS		DRAWING NOT TO SCALE		SHEET NO: 1 OF 1
REV.	DESCRIPTION	ECN	DATE	INIT.				

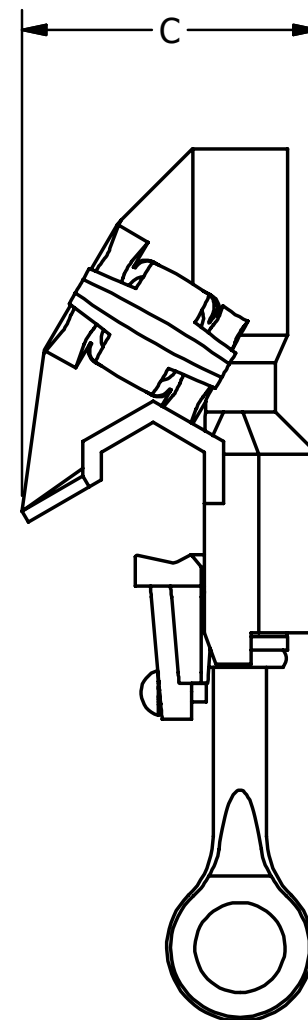
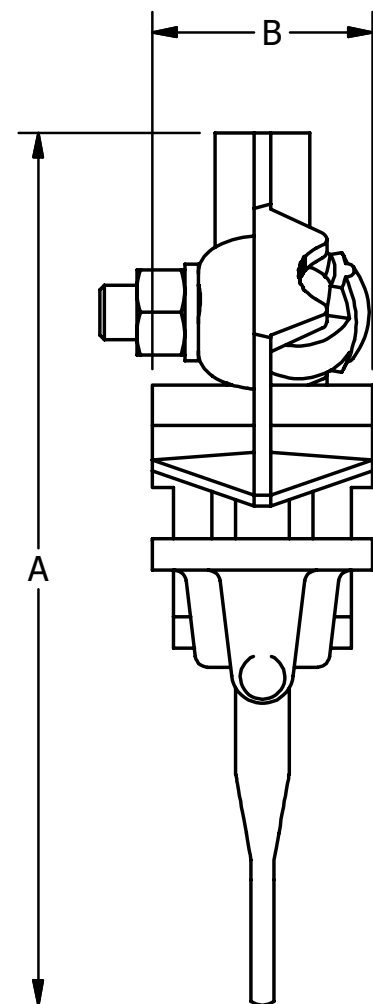
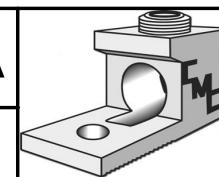

THIS INFORMATION IS PROPRIETARY TO CONNECTOR MFG. CO. AND IS NOT TO BE DISCLOSED OUTSIDE OF CONNECTOR MFG. CO. WITHOUT A CONFIDENTIALITY AGREEMENT



**CONNECTOR MANUFACTURING CO.**

HAMILTON, OHIO